

CAPACITY	SYMBOL/ SERIAL NO.	CIRCUIT DIAGRAM
AC220~240V, 50/60Hz		
10W		

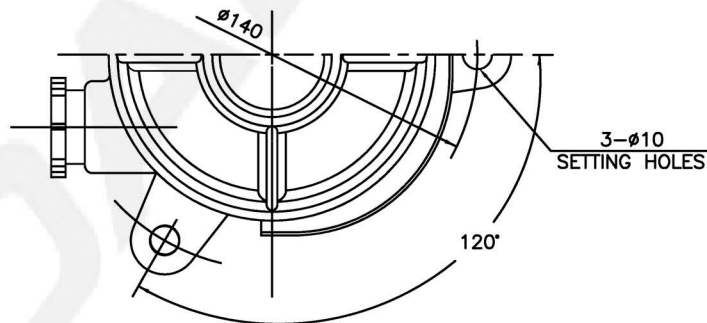
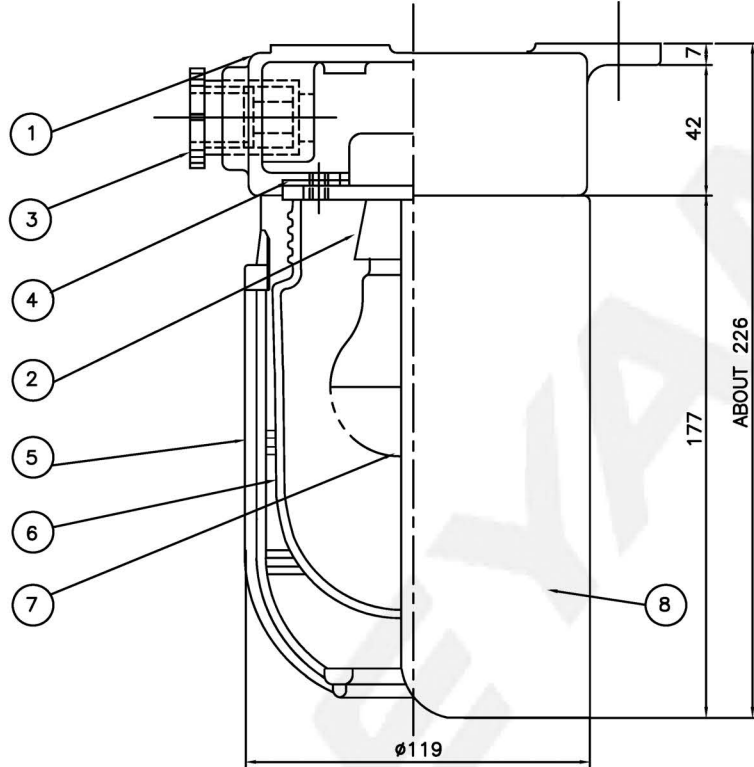

8	SCREEN	STS316	1		4	GLOBE PACKING	SILICON	1	
7	LED BULB	ASS'Y	1	4,000K	3	CABLE GLAND	BRASS	2	ø9~11
6	GLOBE	GLASS	1	S-90	2	LAMP HOLDER	PORCELAIN	1	E27
5	GUARD	BRASS	1		1	BODY	CAST BRASS	1	
NO.	NAME OF PARTS	MATERIAL	Q'TY	REMARKS	NO.	NAME OF PARTS	MATERIAL	Q'TY	REMARKS

APPROVED	J. W. PARK	UNIT	MM	TITLE; SHIP NAME LIGHT FOR MARINE USE					
CHECKED	S. M. SON	SCALE	N/S						
DRAWING	B. K HWANG	COLOR	NATURAL						
DATE	2023.10.06	IP	56						
				MODEL NO.	LP10-23BNCSC40	WEIGHT	2.04 kg		
				DWG NO.	LP1100215	SHT NO.	-		